

PR052 TWO WAYS COAXIAL REFLEX STAGE MONITOR

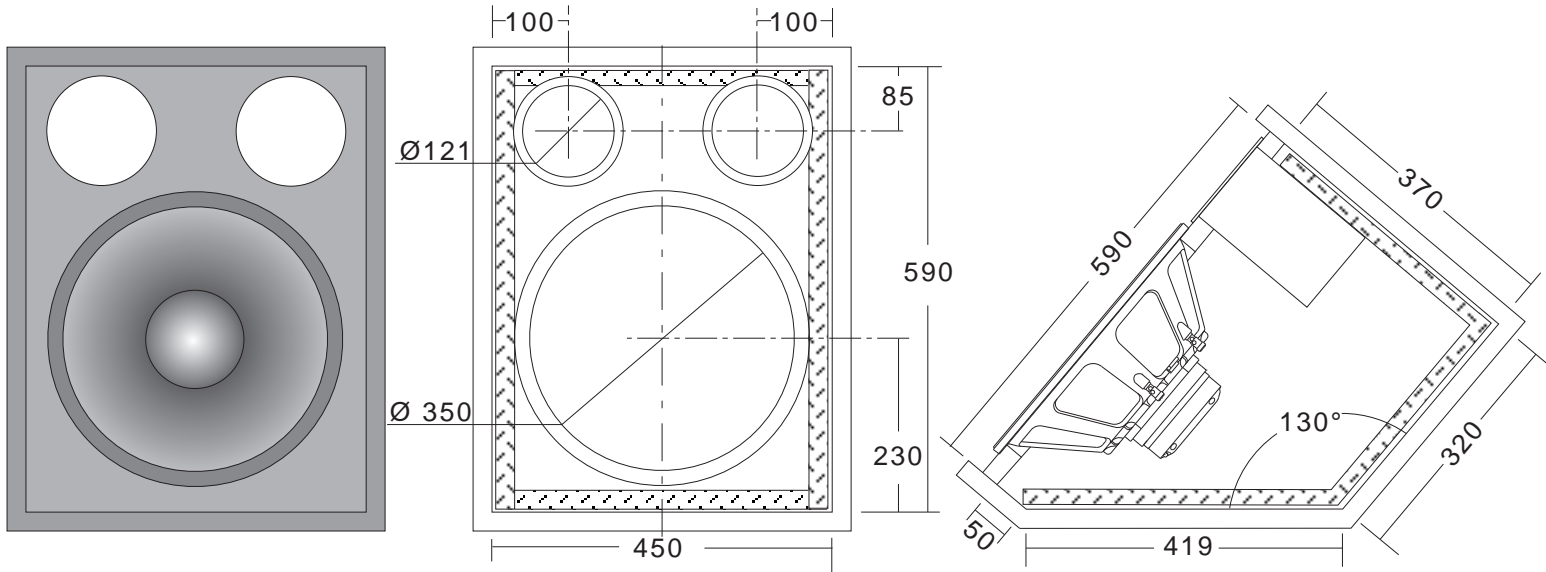

COMPONENTS	
L F / H F	15.2 Nd CX
Max Power	600 W
Nominal Power	300 W
Impedance	8 Ω

SPECIFICATIONS

Sensitivity 1W/1m	:	100	dB
Net volume Vb	:	70	dmc
Tuning Frequency Fb	:	50	Hz
Frequency range	:	20 ÷ 20000	Hz
Crossover Frequency	:	2000	Hz

